

REINHELDT
CHROMATOGRAPHY

R 2500 Series

HPLC SYSTEM

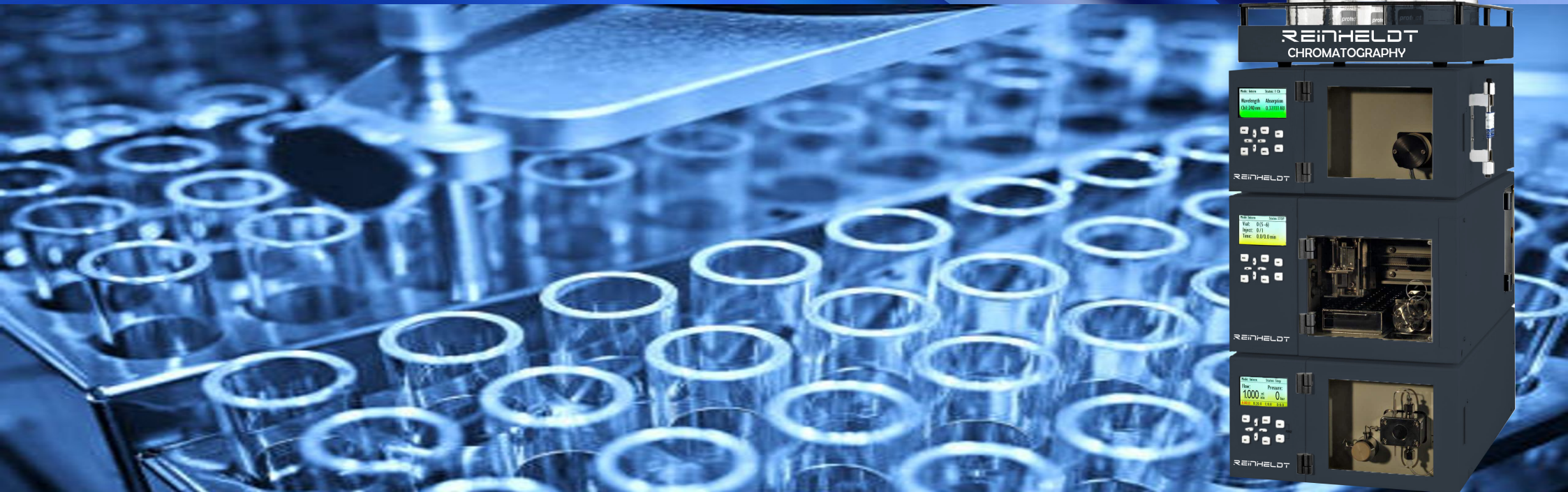

The Reinheldt HPLC System R 2500 Series is intended for all routine analysis as well as for the ambitious analyst. The system configuration is highly variable and several upgrade options make this system suitable for the whole range of analytical applications.

R 1250 HPLC PUMP SYSTEM

The Reinheldt R 1250 HPLC Pump System is a very flexible and powerful HPLC solvent delivery system. Its modular setup makes the R 1250 one of the most versatile pump systems on the market. The possible configurations include an Isocratic or Quaternary Gradient Pump.



Figure: R1250 Isocratic Flowchart

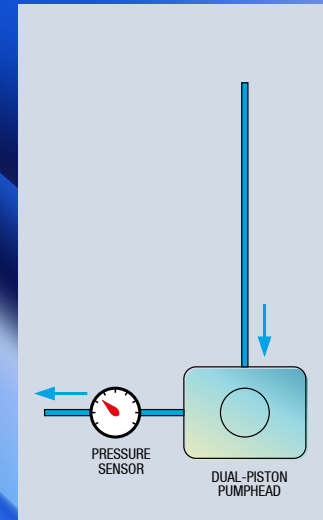

*** Stepper Motor**

The R1250 is driven by a high-power stepper motor. The stepper motor has a much better resolution in the low-flow range than a conventional DC motor.

*** Active Mixer**

The R 1250 low pressure gradient module has an active mixer to achieve highly precise and accurate gradient results.

*** Lubrication**

The R 1250 camshaft is constantly lubricated within a sealed chamber to guarantee long lifetime and low maintenance.

*** Dual-Piston Pump head**

The R 1250 pumps use a dual-piston pump head for low pulsation. Together with electronic pressure compensation the R 1250 pumps are suitable for all analytical tasks in HPLC and GPC.

*** Optional: Piston Back flushing**

The R 1250's pump head incorporates an optional active piston back flushing system.

OnePump-TwoConfigurations

Figure: R 1250 GLP Gradient Flowchart

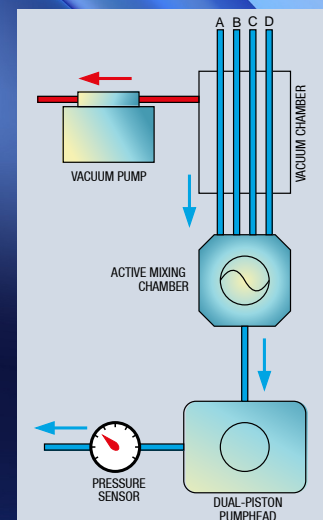

R 1250 Configurations



* R1250 Isocratic HPLC Pump

The R 1250 Isocratic Pump is a robust, low-pulsation solvent delivery system. The pump head is easily accessible from the front panel to make routine maintenance, like changing pump seals, easy and fast. The system is available with Micro, Analytical or Semi-Preparative pumphead in Stainless Steel or PEEK.

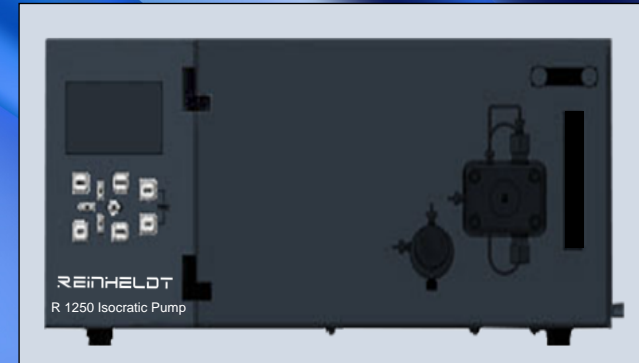

* R1250G Low-Pressure Quaternary Gradient Pump

The R1250 G Low-Pressure Quaternary Gradient Pump incorporates an active low pressure mixer with adjustable mixing volume. The mixing chamber volume can be freely adjusted. An optional integrated vacuum degasser removes dissolved gases in the eluents and prevents air bubbles in the system. The system is available with Micro, Analytical or Semi Preparative pumphead in Stainless Steel or PEEK.

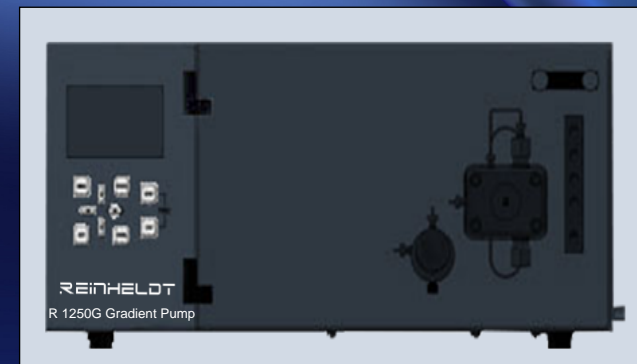

REINHELDT

CHROMATOGRAPHY

R 1250G Quaternary Gradient Pump

* Vacuum Degassing:	<i>optional:</i> < 20% dissolved gases remaining in water @ 1.000 ml/min
* Gradient Range:	0.0 – 100.0 %, 4 channels
* Gradient Accuracy:	< 0.50 %
* Gradient Mixing:	Active
* Mixer Volume:	adjustable: 10 – 500 µl

Technical Specifications

* Wetted Materials:	Stainless Steel / PEEK*, Teflon AF®, PVDF, Ceramics, Sapphire, Ruby
* Flow Rate:	Programmable Micro: 0.001 - 4.000 ml/min Analytical: 0.001 - 10.000 ml/min Semi-Preparative: 0.1 - 40.000 ml/min
* Flow Accuracy:	± 1.0 % 1.000 ml / min
* Flow Precision:	± 0.1 % RSD 1.000 ml/min
* Pressure Range:	0 – 40 MPa (0 – 6000 PSI) Semi-Preparative: 20 MPa (up to 20.000 ml/min); 10 MPa (up to 40.000 ml/min)
* Pressure Pulsation:	typical < 0.1 MPa or < 1.0 %
* Compressibility	user-adjustable for different solvents
* Compensation:	
* Dimensions:	310 x 165 x 478 mm
* (W x H x D)	
* Power Supply:	100 - 250 ~V (47 - 63 Hz)

* Depending on Configuration

* Stepper Motor

The R 1250 is driven by a high-power stepper motor. The stepper motor has a much better resolution in the low flow range than a conventional DC motor.

* Dual-Piston Pumphead

The R 1250 pumps use a dual-piston pumphead for low pulsation. Together with electronic pressure compensation the R 1250 pumps are suitable for all analytical tasks in HPLC and GPC.

* Lubrication

The R 1250 camshaft is constantly lubricated within a sealed chamber to guarantee long lifetime and low maintenance.

* Optional: Active Piston Backflushing

The R 1250 's pump head incorporates an automatic piston backflushing system.

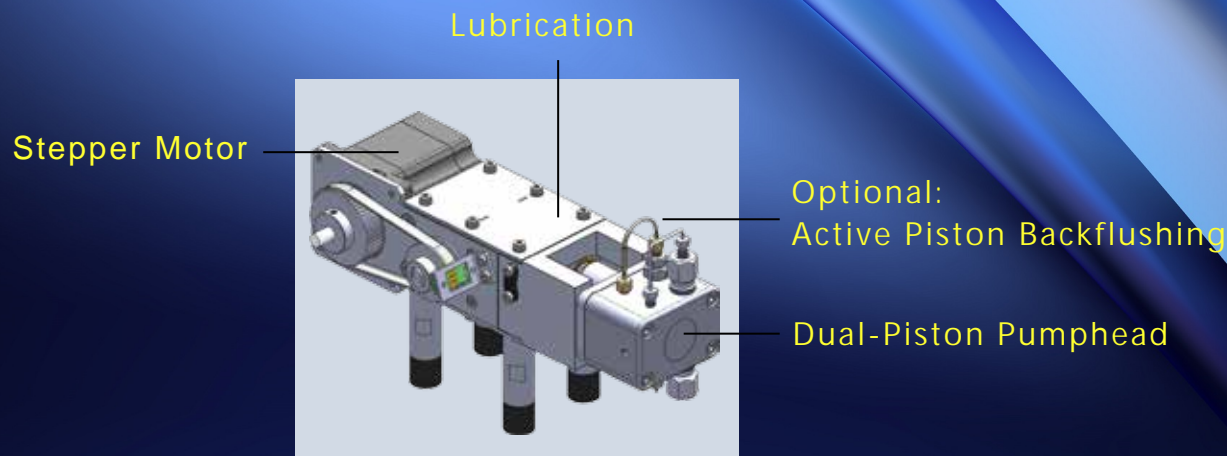

R 250 SAMPLE INJECTOR SYSTEM



The Reinheldt R 250 Sample Injector System is a very flexible and powerful HPLC auto sampler with excellent reproducibility and linearity properties. Variable vial racks and adaptors for microtiter plates as well as a multitude of firmware options make this system highly adaptable and suitable for any analytical application.

Robust Design

* Durable X/Y/Z-Sampling

The R 250 Sample Injector System features a mechanically durable X/Y/Z-Sampling-Mechanic designed for long life operation. The self-lubricating bearings keep the routine maintenance at a minimum and avoid troubles caused by dusty environments. High precision stepper motors drive the X/Y axis for accurate positioning. Microstepping mode enables a high resolution for the syringe dosing and vial positioning.

* Accessibility

The injection valve with sample loop and injection port can be accessed directly from the instrument front without removing any protective covers. The dosing syringe can be accessed from the side of the instrument through a hinged glass panel. The exchange of the syringe can be done without the requirement of any tools.

* Dual-Needle Design

The Dual-Needle design of the R 250 Sample Injector System avoids system blockages caused by septum particles injected into the system. The ventilation needle pierces the septum before the injection needle moves into the sample vial (see figure on the left). As the more fragile injection needle does not need to pierce the vial septum, stronger vial caps or plastic vials can be used without problems.

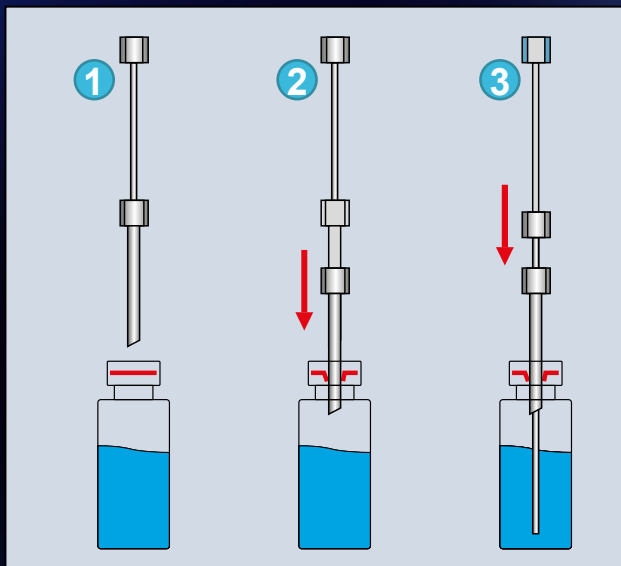

Figure: Dual-Needle Injection

Precision & Modularity

* Performance

The Reinheldt R 250 Sample Injector System offers multiple injection modes depending on application and sample needs. Besides fixed loop overfilling and variable volume injection the instrument offers a Zero-Waste injection mode for injecting very small sample amounts by moving the sample into the middle of the sample loop. Linearity and injection precision can be optimized for any volume by different sample loops and syringe sizes.

* Modular Options

The modular nature of the Reinheldt R 250 Sample Injector System offers the possibility to “just buy what you need”. Modular options include sample heating/cooling for any sensitive sample material and derivatization for automatized pre-column derivatization tasks from reagent derivatization to automatic sample dilution.

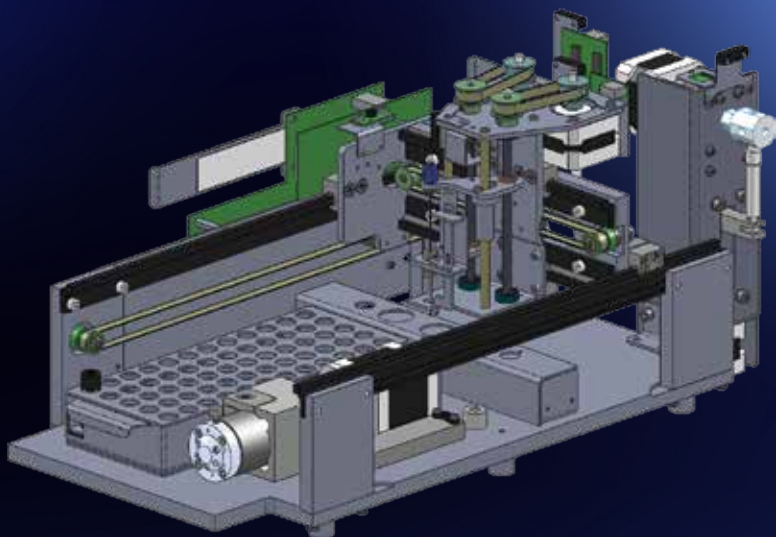

Technical Specifications

* Wetted Materials:	Stainless Steel / PEEK*, PPS, PVDF
* Sample Capacity:	60/80 (1.5 ml), 98 (microtiter plates)
* Injection Volume:	Programmable 0.1 - 999.9 μ l
* Injection Precision:	< 0.5 % Variable Volume Injection (10 μ l; typically \sim 0.25 %)
* Linearity:	Correlation Factor > 0.999 (10 μ l injection volume, 500 μ l Syringe)
* Carry Over:	< 0.05 % with wash program
* Dimensions:	310 x 210 x 478 mm
* (W x H x D)	
* Power Supply:	100 - 250 \sim V (47 - 63 Hz)

* depending on configuration

R 245 UV/VIS DETECTOR

The Reinheldt R245 UV/Vis Detector is a variable wavelength UV/Vis detector for routine analysis and sophisticated research. The dual lamp design offers a wavelength range of 190 – 800nm with a low base-line noise. The front-accessible flow cell can be easily exchanged, as well as the lamps which are accessible through a side panel in the instrument housing.



* Integrated Wavelength Program

The R 245 UV/Vis Detector features a wavelength program to change the selected wavelength over time. With this feature the optimum wavelength can be selected for each analyzed substance according to its retention time.

* Optional – Dual-Wavelength

The R245 UV/Vis Detector is available with an optional second wavelength. This feature enhances the Wavelength Program feature that you can measure 02 different wavelengths at the same time. A second D/A converter output comes with this option to keep the system flexible to be used with any data acquisition software available.

* Optional – Online-Scan

Another option for the R 245 UV/Vis Detector is the Online Scan. With the Online Scan whole spectrum information can be gathered at a certain time. This scan information is stored internally and can be accessed at any time. The Online Scan is a good alternative to a full UV PDA detector.

* Integrated Peak Detector

The integrated Peak Detector works as a basic fraction collector. The peak detection level can be freely programmed for peak start and peak end to enhance the collection purity. An integrated 24V output for switching a solenoid valve is used for the fraction collection, which is automatically operated with a selectable time delay.

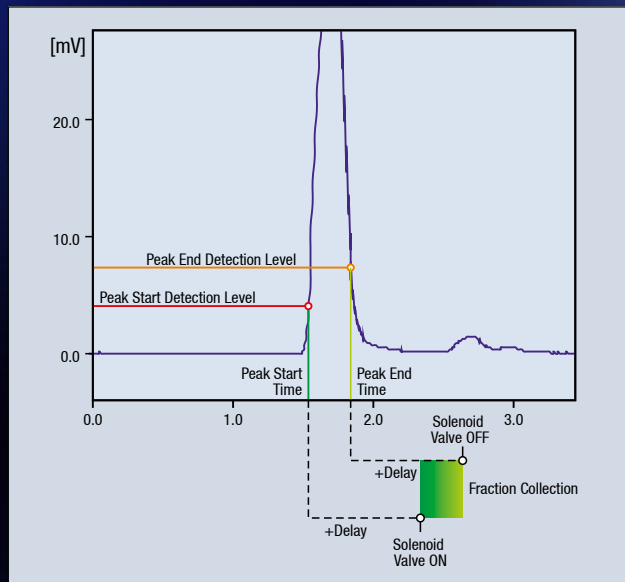

Figure: R245 PeakDetector

Principle of Operation

Technical Specifications

* Wetted Materials:	Stainless Steel / PEEK*
* Baseline Noise:	$\pm 1 \times 10^{-5}$ AU (@240 nm, 2 sec. Risetime)
* Baseline Drift:	$< 3 \times 10^{-4}$ AU/h
* Wavelength Range:	190 – 800 nm
* Wavelength Accuracy:	± 2 nm
* Linearity:	> 2.0 AU
* Light Source	Deuterium Lamp, Tungsten Lamp
* Wavelength Program:	Programmable, 10 steps
* Analog Output:	1x 1 V (<i>optional</i> : 2x 1V)
* Control Features:	Internal Peak Detector with +24 V solenoid switching output.
* Dimensions:	310 x 165 x 478 mm
* (W x H x D)	
* Power Supply:	100 - 250 ~V (47 - 63 Hz)

* Depending on configuration

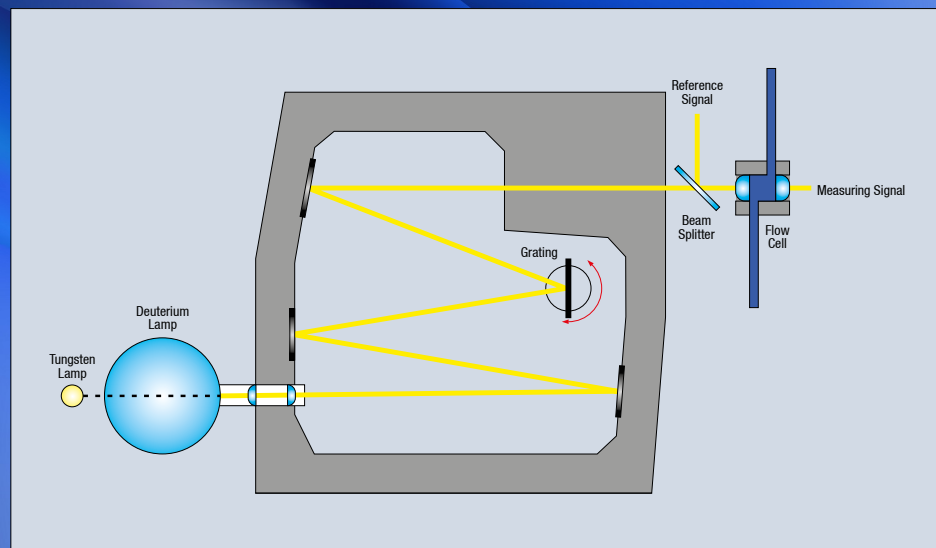

Figure: Principle of Operation

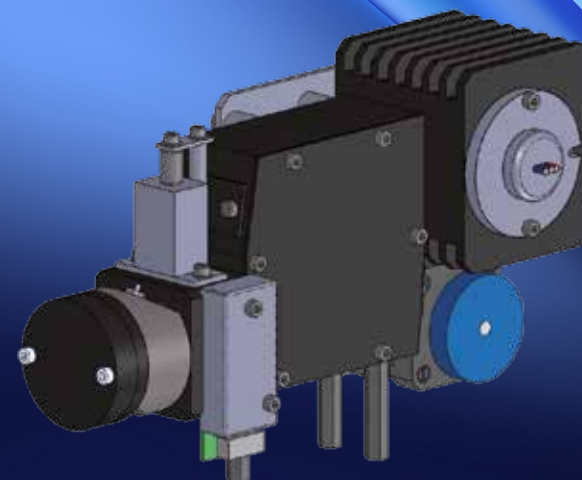

Figure: R 245 Optical Module

R 345 PDA DETECTOR

The Reinheldt R345 UV/Vis Detector is a photo-diode-array (PDA) detector for routine analysis and sophisticated research. The dual lamp design offers a wavelength range of 190–720nm (256 Diodes) or 190-1015nm (1024 diodes) with a low baseline noise. The front-accessible flow cell can be easily exchanged as well as the lamps which are accessible through a side panel in the instrument housing.



* Integrated Peak Detector

The integrated Peak Detector works as a basic fraction collector. The peak detection level can be freely programmed for peak start and peak end to enhance the collection purity. An integrated 24V output for switching a solenoid valve is used for the fraction collection, which is automatically operated with a selectable time delay.

* 4 Channel UV Detector

The R 345 PAD Detector features 4 wavelength channels to measure chromatograms at 4 different wavelengths at the same time. With this feature the optimum wavelength can be selected for each analyzed substance.

* Optional – Analog Output

The R 345 PDA Detector is available with an optional 4-Channel analog output. This D/A converter output option is offered to keep the system flexible to be used with any data acquisition software available.

Technical Specification

* Wetted Materials:	Stainless Steel / PEEK*, Teflon, Glas
* Baseline Noise:	$\pm 1 \times 10^{-5}$ AU (@240 nm, 1 sec. Risetime)
* Baseline Drift:	$<3 \times 10^{-4}$ AU/h
* Number of Diodes:	256 or 1024
* Wavelength Range:	190 – 720 nm (256 Diodes) 190 – 1015 nm (1024 Diodes)
* Wavelength Accuracy:	0.5 nm (256 Diodes); 0.3 nm (1024 Diodes)
* Mean Pixel Pitch:	2.2 nm (256 Diodes), 0.8 nm (1024 Diodes)
* Resolution (λ, FWHM):	7 nm (256 Diodes), 3 nm (1024 Diodes)
* Linearity:	> 2.0 AU
* Light Source	Deuterium Lamp, Tungsten Lamp
* Wavelength Program:	Programmable, 10 steps
* Analog Output:	- (optional: 4x 1V)
* Data Rate:	1 Hz - 100 Hz
* Control Features:	Internal Peak Detector with +24 V solenoid switching output.
* Dimensions:	310 x 165 x 478 mm
* (W x H x D)	
* Power Supply:	100 - 250 ~V (47 - 63 Hz)

* Depending on Configuration

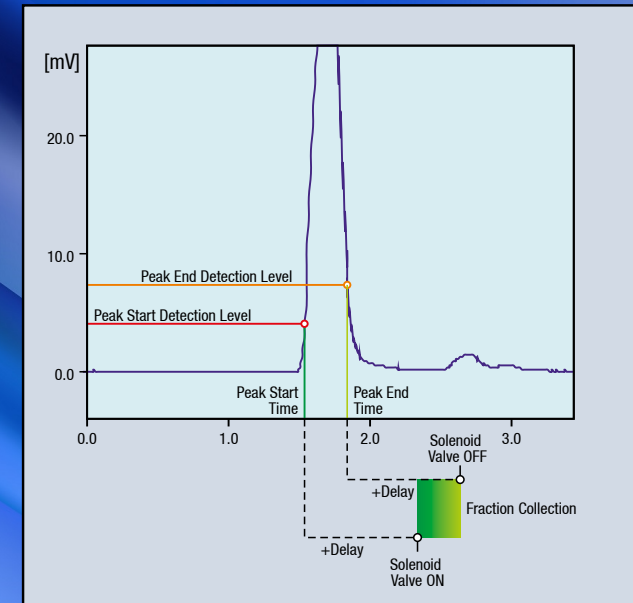

Figure: R 345 Peak Detector

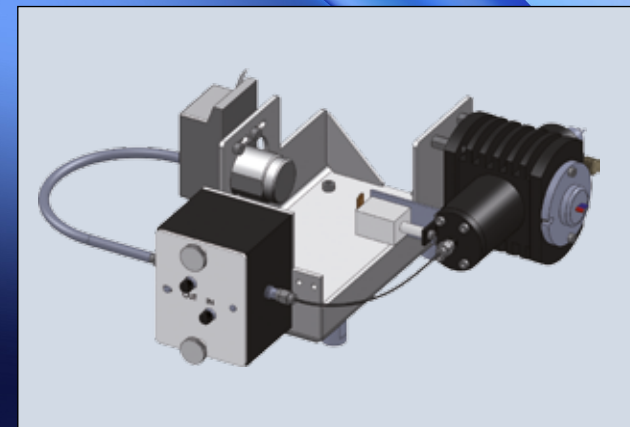

Figure: R 345 Optical Module

R 385 REFRACTIVE INDEX DETECTOR

The Reinheldt R 385 Refractive Index Detector offers the sensitivity, stability and reproducibility required for optimal RI detection.

The thermal isolated optic with a countercurrent heat exchanger and with its programmable temperature control, results in an extremely stable baseline and an optimal Signal /Noise ratio.

The Reinheldt R 385 Refractive Index Detector provides autopurge and autozero capabilities, as well as RS232 communication to acquire data directly without using any external signal interface.



Reinheldt R 385 Refractive Index Detectors are available for:

- **micro**
- **analytical**
- **semi preparative mode**

Technical Specification

	Micro	Analytical	Semi-Preparative
* Detection Method:		Deflection	
* Refractive Index Range:		1.00 to 1.75	
* Flow Rate:	0.2 - 3.0 ml/min	0.2 - 3.0 ml/min	1 - 50 ml/min
* Cell Volume:	4 µl, 45° angle	9 µl, 45° angle	7 µl, 5° angle
* Flow Cell Pressure:	6 kg/cm ²		
* Dead Volume:	6 µl	24 µl	88 or 353 µl
* Linearity Range:	0 - 500 µRIU	0 - 1000 µRIU	0 - 20000 µRIU
* Noise Level:	10 x 10 ⁻⁹ RIU	5 x 10 ⁻⁹ RIU	10 x 10 ⁻⁸ RIU
* Drift with 1ml H₂O/min	< 1mv/hour	< 1mv/hour	< 1mv/hour
* Integrator Output:	± 1 V		
* Recorder Output:	± 10 mV/ 100 mV/ 1 V		
* Recorder Offset:	0 mV/ 10 mV/ 100 mV		
* Recorder Range:	8 steps (1:8) - 16:1)		
* Digital Interface:	RS232, Purge, Autozero, Start, Stop, DataOut: 1 Hz, 10 Hz		
* Digital Output:	TTL: Intensity Alarm		
* Digital Input:	TTL: Purge, Autozero, Start, Marker		
* Temperature Setting:	Ambient, 35°C to 55°C in 1 °C steps, Thermal Fuse 75°C		
* Time Constant:	RAW (0.0 sec.), Fast (0.4 sec.), Medium (0.8 sec.), Slow (1.2 sec.)		
* Weight:	13 kg		
* Dimensions: (W x H x D)	310 x 165 x 478 mm		
* Power Supply:	100-120/220-240 ~V (50/60 Hz), 50 VA		

* All technical specifications may be subject to change.

R 200 COLUMN OVEN

The Reinheldt R200 Column Oven is a contact heat transfer oven for high temperature stability and accuracy. The columns are mounted inside the column oven in optimized column holder which enclose the complete column to get the best temperature transfer between the heater and the column. Up to three 350mm columns can be mounted at the same time.



* Heating

The Reinheldt R200 Column Oven standard version features a high temperature controller for stable column temperatures of +30°C up to +150°C. The temperature accuracy is within 0.1 °C.

* Heating/Cooling

The Reinheldt R200 Column Oven is also available with active Heating/Cooling with Peltier technique. The temperature range is +5°C up to +100°C. The Heating/Cooling unit uses the same efficient controller as the basic version with temperature accuracy better than 0.1 °C.

* Temperature Time Program

The Heating/Cooling variant offers an optional temperature Time Program for stand-alone operation.

* Integrated Valve

The Reinheldt R200 Column Oven offers the option to include an automatic switching valve of the Reinheldt R 600 Valve Series, for example the R 607 Column Selection Valve, but all R 600 Valves can be integrated.



Figure: R 200 Column Compartment

* Leakage Sensor

The R200 Column Oven offers a high sensitive Leakage Sensor which detects the vapors of organic solvents.

* Temperature Fuse

Besides a Leakage Sensor the R 200 offers a temperature fuse which shuts down the unit when the temperature becomes too high, because of an electronic defect.

Technical Specification

* Wetted Materials:	Stainless Steel / PEEK ¹ , PPS ¹
* Temperature Range:	+30°C – +150°C (min.: ambient +5 °C) <i>optional:</i> +5°C – +100 °C (Peltier) ²
* Temperature Accuracy:	< 0.1 °C
* Switching Valve:	<i>optional:</i> any R 600 Series Valve
* Temperature Program:	optional with Heating/Cooling (Peltier)
* Safety Features:	Temperature Fuse; Leakage Sensor
* Dimensions:	183 x 566 x 270 mm
* (W x H x D)	
* Power Supply:	100 - 250 ~V (47 - 63 Hz)

¹ Switching Valve: depending on configuration

² Temperature range at 20°C ambient

R 515 VACUUM DEGASSER

The Reinheldt R515 Vacuum Degasser is an online degasser system with high efficiency. Dissolved gases are removed from the solvents by applying vacuum to a semi-permeable membrane.

* High Efficiency

The high efficient Teflon-AF® capillary has a much higher efficiency than a normal Teflon capillary of similar size. This allows the usage of a smaller length of capillary to reduce the dead volume of the system considerably.

* 2 Operation Modes

The R 515 can be run either with constant speed or in Hysteresis Mode, which switches the vacuum pump on or off.

* 5-Year Membrane Warranty

The R 515 vacuum pump uses a membrane for creating the vacuum. This membrane is made of a specific Teflon material specifically designed for fast movements. Reinheldt offers a 5-year warranty on the lifetime of this membrane.

* Multi-Channel

The R515 Vacuum Degasser is available as 1-Channel, 2-Channel, 3-Channel, or 4-Channel version. Each solvent channel can be used for a different solvent. Several channels can be used in series to increase the efficiency even more.



* Working Principle

The solvent flows through a short length of Teflon AF® capillary inside a sealed chamber. This chamber (vacuum chamber) is completely sealed to the environment and vacuum is applied with a pump. Due to this vacuum any dissolved gases in the solvent running through the inner capillary are removed through its semi-permeable membrane wall. The high efficiency of the Teflon AF® material allows the usage of a very short length of capillary inside the vacuum chamber.

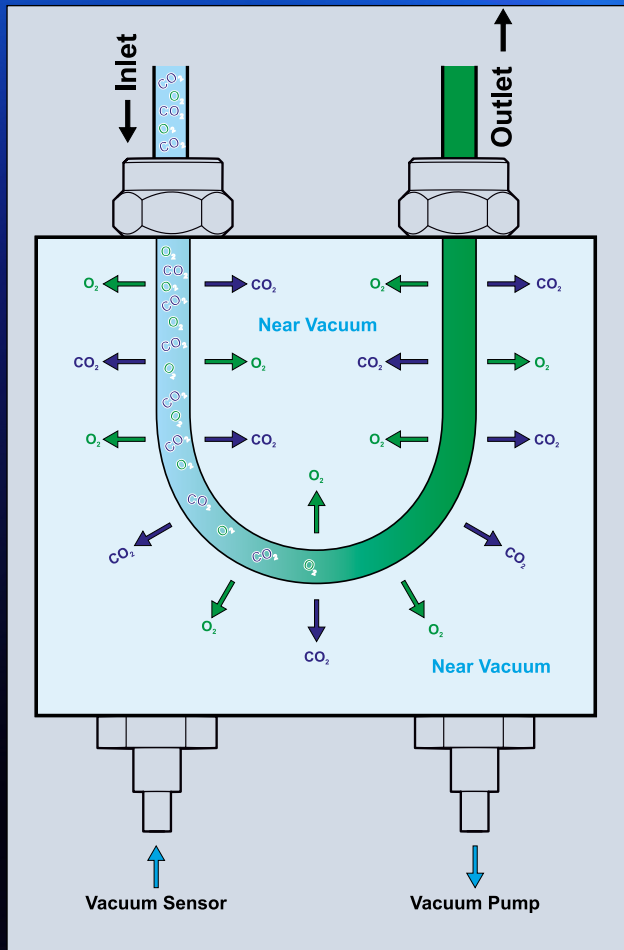

Specifications

* Wetted Materials:	Teflon AF®, Teflon, Stainless Steel, Aluminium, EPDM
* Degassing Capacity:	< 20% dissolved gases remaining in water at 1.0 ml/min
* Volume / Channel:	< 500µl
* Dimensions:	125 x 167 x 270 mm
* (W x H x D)	
* Weight:	3.2 kg
* Power Supply:	100 - 250 ~V (47 - 63 Hz)

REINHELDT
CHROMATOGRAPHY

R 2500 Series

HPLC SYSTEM

Reinheldt GmbH

Feldstr14, 86922Eresing Germany

Tel: +49(0)81939906-108 FAX: +49(0)81939961-409

E-Mail: sales@reinheldtgmbh.de Web: <http://www.reinheldtgmbh.de>